

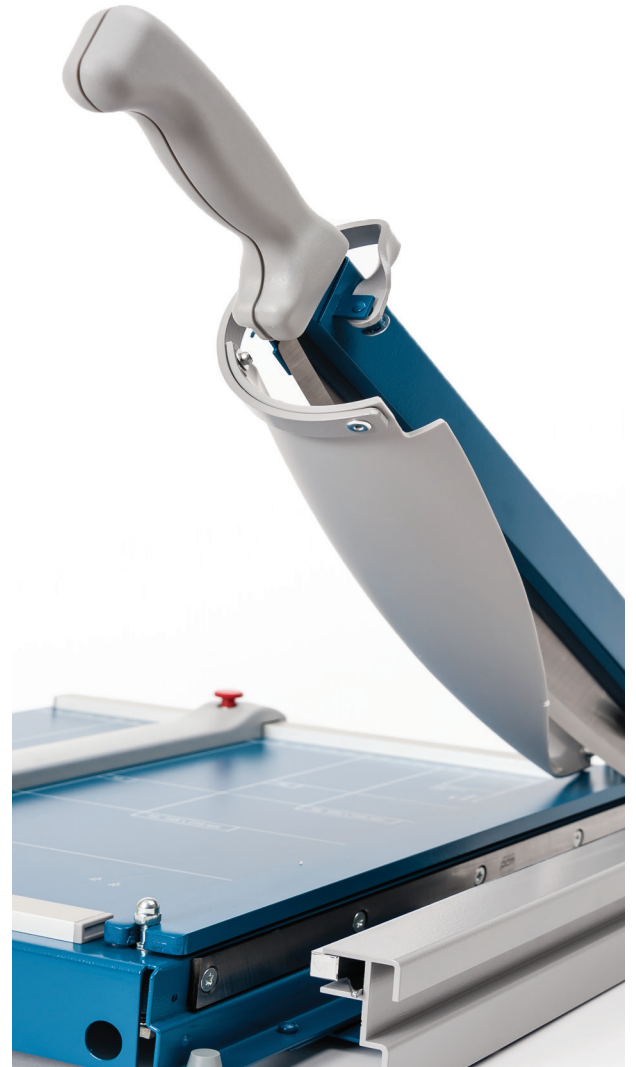

2019 Product Guide

DAHLE[®]
Office Products & Equipment





For over 88 years Dahle has established a reputation for developing the very best office products and equipment. Founded in 1930, Wilhelm Dahle first began producing steel cutting discs for pencil sharpeners. Throughout the years, Dahle's reputation and customer satisfaction has grown worldwide.

DAHLE[®]

About Dahle

Engineered and developed in Germany, the Dahle name is synonymous with quality and innovation. Dahle offers a complete range of cutting, art, and office products that exceed even the most serious demands for performance. All products are factory tested before release to ensure complete customer satisfaction. Using the strictest standards for quality and safety, each cutting edge is precision ground to provide the cleanest cut possible. Our alignment guides are carefully squared by hand to provide the accuracy our customers have come to expect from Dahle.

Whether you are trimming a single sheet of paper or a stack of 700, Dahle paper cutters will give you the results you desire. These precision trimmers have the ability to shave the tiniest sliver from your paper. Results of this caliber are made possible from over 88 years of experience.

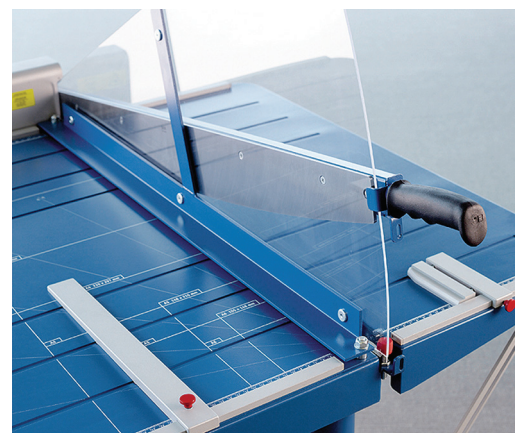

Rolling Trimmers

Dahle rolling trimmers are designed for safety and accuracy. They feature a ground, self-sharpening rotary blade that cuts in either direction. It's this sharpening action that helps the trimmer maintain a perfectly

honed edge, and produce a clean, burr-free cut. An automatic clamp and carefully screened guides ensure accuracy.

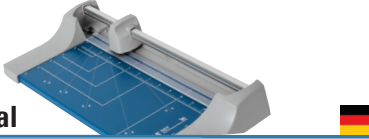

Personal

Model	Cut	Capacity
507	12 1/2"	7 Sheets
508	18"	7 Sheets

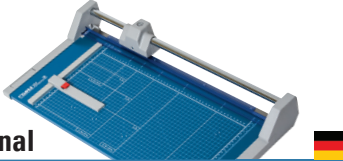

Professional

Model	Cut	Capacity	Stand
550	14 1/8"	20 Sheets	
552	20"	20 Sheets	
554	28 1/4"	20 Sheets	
556	37 3/4"	14 Sheets	#696
558	51 1/8"	12 Sheets	#698

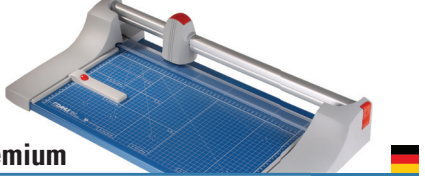

Premium

Model	Cut	Capacity	Stand
440	14 1/8"	30 Sheets	
442	20"	30 Sheets	
444	26 3/8"	25 Sheets	
446	36 1/8"	22 Sheets	#796
448	51 1/8"	20 Sheets	#798
472	72"	12 Sheets	#799

Large Format Rolling Trimmers

Perfect for larger applications, these heavy duty trimmers include a sturdy metal stand and paper catch. They feature a ground, self-sharpening cutting blade that cuts in either direction. The compact stand provides the perfect height for trimming. Premium Series trimmers will cut mat board.



Professional

Model	Cut	Capacity	Stand
556 S	37 3/4"	14 Sheets	Included
558 S	51 1/8"	12 Sheets	Included

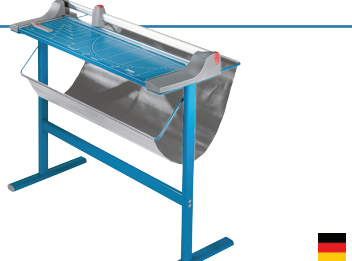

Premium

Model	Cut	Capacity	Stand
446 S	36 1/8"	22 Sheets	Included
448 S	51 1/8"	20 Sheets	Included
472 S	72"	12 Sheets	Included

Guillotines

Dahle Guillotines offer innovative safety features that include either a hand guard or a rotary safety shield. Pro and Premium models feature a ground, self-sharpening

blade that produces a clean, burr-free cut. An easily adjustable backstop saves time and ensures accuracy during repetitive cutting.



Vantage®

Model	Cut	Capacity
12e	12"	15 Sheets
15e	15"	15 Sheets
18e	18"	15 Sheets

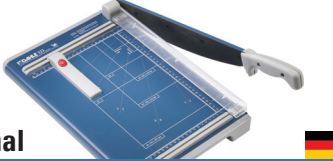

Professional

Model	Cut	Capacity
533	13 3/8"	15 Sheets
534	18"	15 Sheets
560	13 3/8"	25 Sheets



Premium

Model	Cut	Capacity
561	14 1/8"	35 Sheets
564	14 1/8"	40 Sheets
565	15 1/8"	35 Sheets
567	21 3/8"	35 Sheets
569	27 1/2"	35 Sheets

Large Format Guillotines

Large Format Guillotines are perfect for oversize applications. They feature a ground, self-sharpening blade for precision and an acrylic safety shield. The trimmer's integrated stand ensures optimal cutting height. They're perfect for trimming paper, cardstock, and matboard. An optional laser guide guarantees accuracy.



Premium

Model	Cut	Capacity	Laser
580	32"	30 Sheets	#797



Premium

Model	Cut	Capacity	Laser
585	43 1/4"	30 Sheets	#797

Stack Cutters

Professional Stack Cutters are designed for safe, easy cutting of large volumes of paper. They feature a machine ground blade for extreme accuracy and protective guards to keep fingers safe. The cutter's carefully

engineered paper clamp ensures even pressure and prevents paper shift. Cutters are shown on optional stand which ensures proper trimming height.



Model	Cut	Capacity	Stand
842	16 7/8"	200 Sheets	#712



Model	Cut	Capacity	Stand
846	16 7/8"	500 Sheets	#712



Model	Cut	Capacity	Stand
848	18 3/8"	700 Sheets	#718

Scissors

Dahle Vantage® Scissors are lightweight and versatile for many applications. They feature machine ground, stainless steel blades that resist rust, and contoured handles to reduce pressure points. These scissors are great for trimming paper, photo paper, and cardstock.



Vantage® Scissors

Model	Size
40005	5"
40006	6"
40008	8"



Vantage® Comfort-Grip Scissors

Model	Size
40025	5"
40026	6"
40028	8"

Sharpeners

Dahle offers many sharpening solutions to ensure you're ready when creativity strikes. These sharpeners are perfect for graphite, color, and oversize wax pencils. Rotary sharpeners feature an Automatic

Cutting System for convenience, and a point adjuster to prevent over-sharpening.



Lead Pointers - for 2mm leads

Model	Description
53484	Compact Lead Pointer
301	Precision Lead Pointer



Rotary Sharpeners

Model	Description
133	Personal Rotary Sharpener
155	Pro Rotary Sharpener
166	Premium Rotary Sharpener



Rotary Sharpeners

Model	Description
53459	Metal Wedge Sharpener
53485	Metal Double Hole Wedge
53461	Canister Sharpener
53463	Canister Sharpener
53465	Double Hole Canister
53460	Chubby Canister Sharpener

Vantage® Cutting Mats

Protecting your work surface is the function of a cutting mat, but there's a lot more to Dahle's Vantage® Self-Healing Mats.

These mats are self-healing and constructed using 5 layers of PVC plastic. It's this specialized formation of plastic that allows

cuts to just disappear— which greatly prolongs the life of the mat.

Black Mats

Model	Size
10670	9" x 12"
10671	12" x 18"
10672	18" x 24"
10673	24" x 36"
10674	36" x 48"

Blue Mats

Model	Size
10690	9" x 12"
10691	12" x 18"
10692	18" x 24"
10693	24" x 36"
10694	36" x 48"

Clear Mats

Model	Size
10680	9" x 12"
10681	12" x 18"
10682	18" x 24"
10683	24" x 36"
10684	36" x 48"

Standard Clinch Staplers

The compact Novus B4 and the larger B5 feature a steel driven stapling mechanism that provides superior performance and reduces jams. These staplers produce a standard clinch, temporary pin, or tack, and have a max capacity of up to 40 sheets.



Novus B4 

Color	Depth	Dimensions
Black	2 3/8"	5 3/8" x 1 1/2" x 2 1/2"
Blue	2 3/8"	5 3/8" x 1 1/2" x 2 1/2"
Gray	2 3/8"	5 3/8" x 1 1/2" x 2 1/2"





Novus B5 

Color	Depth	Dimensions
Black	4 1/8"	7" x 1 1/2" x 2 1/2"
Blue	4 1/8"	7" x 1 1/2" x 2 1/2"
Gray	4 1/8"	7" x 1 1/2" x 2 1/2"

Flat Clinch Staplers

Novus Flat Clinch Staplers press the staple legs flat for up to 30% more filing space. Both sizes feature a steel driven stapling mechanism that provides superior performance and reduces jams. These staplers produce a flat clinch, temporary pin, or tack, and have a max capacity of up to 50 sheets.



Novus B4Fc 

Color	Depth	Dimensions
Black	2 3/8"	5 3/8" x 1 1/2" x 3"
Blue	2 3/8"	5 3/8" x 1 1/2" x 3"
Gray	2 3/8"	5 3/8" x 1 1/2" x 3"



Novus B5Fc 

Color	Depth	Dimensions
Black	3 3/8"	7 3/8" x 1 5/8" x 3"
Blue	3 3/8"	7 3/8" x 1 5/8" x 3"
Gray	3 3/8"	7 3/8" x 1 5/8" x 3"

B8Fc Power-On-Demand Stapler

The innovative Novus B8Fc incorporates the industry's only Power-on-Demand (POD) technology that requires 70% less effort to staple. Just lift the top lever and experience the benefits of stapling up to 50 sheets of

paper from across your desk! The B8Fc produces a flat clinch, temporary pin, or tack to provide up to 30% more filing space.



Color	Depth	Dimensions
Black	2 3/8"	7 7/8" x 1 7/8" x 3 3/8"

B17 Long Arm Stapler

The Novus B17 is a unique stapler with an 11 3/4" reach. It features an adjustable depth guide to ensure you staple at the desired location each and every time. With the

added ability of temporary pinning, the B17 is ideal for stapling across large documents, binding booklets, and everyday stapling. Max capacity up to 40 sheets.



Depth	Dimensions
11 3/4"	16 1/2" x 2 3/8" x 2 3/4"

Heavy Duty Staplers

Designed and developed in Germany, these rugged staplers are capable of continually stapling large quantities of paper with minimal effort. They feature an innovative Anti-Blocking System (ABS) which prevents the possibility of a staple jam. A depth guide and Automatic Bypass System is standard on all models.



Model	Capacity	Throat	Anti-Jam	Bypass	Warranty	Dimensions
B40	100 Sheets	2 1/8"	•	•	10 Years	10 1/2" x 2 3/4" x 5 3/4"
B50	140 Sheets	3"	•	•	25 Years	14" x 4 1/2" x 6 3/4"
B52	20-170 Sheets	4 1/4"	•	•	25 Years	12" x 4" x 10 7/8"
B54	20-170 Sheets	9 7/8"	•	•	25 Years	17 3/4" x 4" x 11"
B56	20-210 Sheets	3"	•	•	25 Years	14 1/4" x 3 1/2" x 10 1/4"

Premium Staples

Model	Length	Quantity
24/6 Super	6mm	1000
24/8 Super	8mm	1000
23/8 Super	8mm	1000

Model	Length	Quantity
23/10 Super	10mm	1000
23/13 Super	13mm	1000
23/15 Super	15mm	1000

Model	Length	Quantity
23/17 Super	17mm	1000
23/20 Super	20mm	1000
23/24 Super	24mm	1000



Document Destruction

Secure information should never fall into the wrong hands. Dahle paper shredders are your best line of defense in preventing unauthorized access to secure information. Whether it's personal credit card statements or Top Secret government documents, Dahle has a shredder that will meet your needs.

Features- With Dahle, you can choose the features that matter most to you. Whether you prefer the ease of oil-free shredding, or the relief from fine dust filtration, Dahle has you covered. Rest assured that no matter what you choose, all Dahle shredders are German engineered and guaranteed to provide many years of trouble free operation.

DAHLE CleanTEC® Air Filtration



- Traps harmful fine dust
- Improves air quality at work
- Provides a healthier environment

Automatic EvenFlow Lubricator



- Provides slow, continuous oil
- Reduces heat & friction
- Maintains peak performance

German Engineered



- Over 88 years of experience
- Latest technology & design
- Trouble free guarantee

Oil-Free Shredding



- Maintenance free / hassle-free
- Maintains peak performance
- Environmentally friendly

SmartPower Energy Management



- Reduces energy consumption
- Saves on electrical costs
- Environmentally friendly

Automatic Jam Protection



- Eliminates frustrating jams
- No shredder down time
- Prevents damage to shredder



Desktop

1 User
Waste Volumes: 4-9 gal.
Security Level: P-4

Small Office

1-3 Users
Waste Volume: 8-23 gal.
Security Level: P-4 to P-7

Office

3-5 Users
Waste Volume: 30-38 gal.
Security Level: P-2 to P-7

Department

5+ Users
Waste Volume: 38-45 gal.
Security Level: P-2 to P-7

High Capacity

5+ Users
Waste Volume: 50 gal.
Security Level: P-2 to P-7

Model	Security Level	Capacity #20 / #16	Shred Size	Waste Volume	Feed Width	Speed feet/min	Decibel Level	Special Features		Features			Staples /Clips	CDs DVDs	Warranty Shredder /Cylinders	Dimensions length x width x height	Weight
								Oil-Free	CleanTEC®	Jam Protection	Smart Power	Auto Oiler					

Deskside Shredders (1 user)

22022	P-4	7 / 9	3/16" x 1 3/16"	4 gal.	8 3/4"	10 f/m	59 dB	Oil-Free		●					1 year / 5 years	7" x 12 1/2" x 15 1/2"	8 lbs
22092	P-4	10 / 12	3/16" x 1 3/8"	4 gal.	8 3/4"	14 f/m	62 dB	Oil-Free		●					1 year / 5 years	7 3/4" x 12 1/4" x 16 1/2"	14 lbs
22312	P-4	15 / 17	3/16" x 1 7/16"	7 gal.	8 3/4"	9 f/m	53 dB	Oil-Free		●					1 year / 5 years	11" x 14 1/4" x 21"	24 lbs
22318	P-4	16 / 18	3/16" x 1 1/8"	9 gal.	8 3/4"	11 f/m	52 dB	Oil-Free		●					1 year / 5 years	13" x 15 1/2" x 25 1/2"	32 lbs

Small Office Shredders (1-3 users)

50114	P-4	10 / 12	1/8" x 1 1/16"	8 gal.	9 1/2"	22 f/m	44 dB	Oil-Free		●	●				2 years / Lifetime	13 3/4" x 17" x 24 3/4"	46 lbs
50214	P-4	10 / 12	1/8" x 1 1/16"	11 gal.	9 1/2"	22 f/m	46 dB	Oil-Free		●	●				2 years / Lifetime	13 3/4" x 17" x 28"	50 lbs
51214	P-4	10 / 12	1/8" x 1 1/16"	11 gal.	9 1/2"	22 f/m	46 dB	Oil-Free	CleanTEC®	●	●				2 years / Lifetime	13 3/4" x 17" x 28"	56 lbs
50310	P-3	20 / 22	3/16" x 1 1/16"	23 gal.	10 1/4"	20 f/m	46 dB	Oil-Free		●	●				2 years / Lifetime	17 1/4" x 21 1/2" x 34 1/4"	95 lbs
50314	P-4	14 / 16	1/8" x 1 1/16"	23 gal.	10 1/4"	20 f/m	46 dB	Oil-Free		●	●				2 years / Lifetime	17 1/4" x 21 1/2" x 34 1/4"	89 lbs
51314	P-4	16 / 18	1/8" x 1 1/16"	23 gal.	10 1/4"	18 f/m	46 dB	Oil-Free	CleanTEC®	●	●				2 years / Lifetime	17 1/4" x 21 1/2" x 34 1/4"	94 lbs
51322	P-5	12 / 14	1/13" x 3/16"	23 gal.	10 1/4"	18 f/m	46 dB		CleanTEC®	●	●	●			2 years / Lifetime	17 1/4" x 21 1/2" x 34 1/4"	95 lbs
40330	P-6	6 / 8	1/32" x 7/16"	23 gal.	10 1/4"	12 f/m	47 dB			●	●	●			2 years / 1 year	17 1/4" x 21 1/2" x 34 1/4"	94 lbs

Office Shredders (3-5 users)

40406	P-2	30 / 34	1/4"	30 gal.	10 1/4"	22 f/m	51 dB	Oil-Free		●	●				2 years / Lifetime	17 1/4" x 21 1/2" x 36 3/4"	97 lbs
50410	P-3	20 / 22	3/16" x 1 1/16"	30 gal.	10 1/4"	20 f/m	52 dB	Oil-Free		●	●				2 years / Lifetime	17 1/4" x 21 1/2" x 36 3/4"	98 lbs
50414	P-4	16 / 18	1/8" x 1 1/16"	30 gal.	10 1/4"	20 f/m	46 dB	Oil-Free		●	●				2 years / Lifetime	17 1/4" x 21 1/2" x 36 3/4"	95 lbs
51414	P-4	18 / 20	1/8" x 1 1/16"	30 gal.	10 1/4"	18 f/m	52 dB	Oil-Free	CleanTEC®	●	●				2 years / Lifetime	17 1/4" x 21 1/2" x 36 3/4"	100 lbs
51422	P-5	13 / 15	1/13" x 3/16"	30 gal.	10 1/4"	18 f/m	53 dB		CleanTEC®	●	●	●			2 years / Lifetime	17 1/4" x 21 1/2" x 36 3/4"	110 lbs
40430	P-6	9 / 11	1/32" x 7/16"	30 gal.	10 1/4"	20 f/m	52 dB			●	●	●			2 years / 1 year	17 1/4" x 21 1/2" x 36 3/4"	105 lbs
50464	P-4	24 / 26	1/8" x 1 1/16"	30 gal.	12"	20 f/m	52 dB	Oil-Free		●	●				2 years / Lifetime	17 1/4" x 21 1/2" x 36 3/4"	119 lbs
51464	P-4	24 / 26	1/8" x 1 1/16"	30 gal.	12"	18 f/m	52 dB	Oil-Free	CleanTEC®	●	●				2 years / Lifetime	17 1/4" x 21 1/2" x 36 3/4"	118 lbs
51472	P-5	16 / 18	1/13" x 3/16"	30 gal.	12"	18 f/m	53 dB		CleanTEC®	●	●	●			2 years / Lifetime	17 1/4" x 21 1/2" x 36 3/4"	138 lbs

Department Shredders (5+ users)

50514	P-4	26 / 28	1/8" x 1 1/16"	38 gal.	12"	16 f/m	52 dB	Oil-Free		●	●				2 years / Lifetime	20" x 29" x 34 1/2"	144 lbs
51514	P-4	26 / 28	1/8" x 1 1/16"	38 gal.	12"	18 f/m	52 dB	Oil-Free	CleanTEC®	●	●				2 years / Lifetime	20" x 29" x 34 1/2"	143 lbs
51522	P-5	16 / 18	1/13" x 3/16"	38 gal.	12"	18 f/m	53 dB		CleanTEC®	●	●	●			2 years / Lifetime	20" x 29" x 34 1/2"	154 lbs
40530	P-6	10 / 12	1/32" x 7/16"	38 gal.	12"	15 f/m	50 dB			●	●	●			2 years / 1 year	20" x 29" x 34 1/2"	146 lbs
40606	P-2	36 / 40	1/4"	45 gal.	16"	26 f/m	50 dB	Oil-Free		●	●				2 years / Lifetime	20" x 29" x 38"	199 lbs
50564	P-4	20 / 22	1/8" x 1 1/16"	45 gal.	16"	30 f/m	54 dB	Oil-Free		●	●				2 years / Lifetime	20" x 29" x 38"	155 lbs
51564	P-4	22 / 24	1/8" x 1 1/16"	45 gal.	16"	20 f/m	52 dB	Oil-Free	CleanTEC®	●	●				2 years / Lifetime	20" x 29" x 38"	158 lbs
51572	P-5	14 / 16	1/13" x 3/16"	45 gal.	16"	20 f/m	53 dB		CleanTEC®	●	●	●			2 years / Lifetime	20" x 29" x 38"	141 lbs

High Capacity Shredders (5+ users)

20390	P-2	55 / 60	1/4"	50 gal.	16"	22 f/m	60 dB	Oil-Free		●					2 years / Lifetime	24 1/2" x 27 1/2" x 46 3/4"	337 lbs
20396	P-4	38 / 43	1/8" x 1 1/16"	50 gal.	16"	22 f/m	64 dB			●	●				2 years / Lifetime	24 1/2" x 29 1/2" x 46 3/4"	359 lbs
20392	P-5	26 / 28	1/13" x 3/16"	50 gal.	16"	22 f/m	60 dB			●	●	●			2 years / Lifetime	24 1/2" x 29 1/2" x 46 3/4"	359 lbs

High Security Shredders (For Government Use)

20434ds	P-7	4 / 6	1mm x 4.7mm	6 gal.	9 1/2"	13 f/m	50 dB			●	●	●			2 years / 1 year	14" x 16" x 18"	66 lbs
40334	P-7	5 / 7	1mm x 4.7mm	23 gal.	10 1/4"	22 f/m	50 dB			●	●	●			2 years / 1 year	18 1/4" x 21 1/2" x 34 1/4"	94 lbs
41334	P-7	5 / 7	1mm x 4.7mm	23 gal.	10 1/4"	22 f/m	50 dB		CleanTEC®	●	●	●			2 years / 1 year	18 1/4" x 21 1/2" x 34 1/4"	94 lbs
40434	P-7	8 / 10	1mm x 4.7mm	30 gal.	10 1/4"	22 f/m	52 dB			●	●	●			2 years / 1 year	18 1/4" x 21 1/2" x 36 1/4"	105 lbs
41434	P-7	8 / 10	1mm x 4.7mm	30 gal.	10 1/4"	22 f/m	52 dB		CleanTEC®	●	●	●			2 years / 1 year	18 1/4" x 21 1/2" x 36 1/4"	102 lbs
40534	P-7	8 / 10	1mm x 4.7mm	38 gal.	12"	23 f/m	52 dB			●	●	●			2 years / 1 year	21" x 29" x 34 1/2"	146 lbs
41534	P-7	8 / 10	1mm x 4.7mm	38 gal.	12"	23 f/m	52 dB		CleanTEC®	●	●	●			2 years / 1 year	21" x 29" x 34 1/2"	146 lbs
20394	P-7	9 / 11	1mm x 4.7mm	50 gal.	16"	35 f/m	56 dB			●	●				2 years / 1 year	24 1/2" x 29 1/2" x 46 3/4"	245 lbs

*Sheet capacity will vary depending on paper size, weight, quality, and sufficient power

Shredder Supplies

Model	Description
20710	DAHLE CleanTEC® Filter
20721	Dahle Shredder Oil - 6-12 oz. bottles
20722	Dahle Shredder Oil - 1-4 gal. bottles
20723	Shred Bags (200) - 8 gal. shredders
20724	Shred Bags (100) - 11 gal. shredders
20725	Shred Bags (100) - 23 & 33 gal. shredders
20726	Shred Bags (100) - 38+ gal. shredders



The DAHLE Advantage

Command Dial

- 1** Controls all shredder functions including continuous run and reverse

Automatic Jam Protection

- 2** The motor automatically stops and reverses in the event of an overfeed

Door Open Interlock

- 3** Prevents the shredder from running when the door is open

Thermally Protected Motor

- 4** Prevents the motor from overheating during extended use

Rubber Shock Mounts

- 5** Suspends the cutting head to isolate noise and reduce vibration

Chain Driven Motor

- 6** Provides continuous power and slip-free performance to the cutting cylinders

Gusseted Shred Bag

- 7** Expanding folds and 3 mil. strength allow for maximum shred capacity

Wooden Cabinet w/ Casters

- 8** Attractive, modern design blends with any office decor or workplace

SmartPower Energy Management

- 9** Automatically reduces power consumption when idle, and saves money

CleanTEC® Fine Dust Filter

- 10** Eliminates up to 98% fine dust and provides a healthier workplace

**Some components not available on certain models*



NOVUS® **DAHLE**®

Dahle North America, Inc.
49 Vose Farm Road
Peterborough, NH 03458
(800) 995.1379 / www.dahle.com



Authorized Distributor



CRD Distribution Inc
Phone: (877) 974-3678
www.crddistribution.ca

